

WATERMARKED RISING SPINDLE RESILIENT SEATED GATE VALVE FLANGED ENDS

FEATURES

- Ductile iron body, SS431 stem
- Resilient seat
- Outside screw and yoke, clockwise closed
- Fusion bonded epoxy coated to AS 4158
- Potable water approved to AS 4020
- Certified to AS 2638.2

OPTIONS

- Gearbox operated
- Actuation Fitted
- Non rising stem
- Grooved Connection

TECHNICAL DATA

- Code: VG3299S-WM-16-E(size DN) *Flanged*
- Size Range: DN80 – 300 *Flanged*
DN100 – 150 *Grooved*
- Flange Drilling: AS 4087/ AS 2129 Table D/E
- Working Pressure: PN16 (232 psi)



Model # XZ41X

DIMENSIONS

DN	FxF	C	L	Close H1	Open H1	D	φD1	d	n-φd1
80	203	18	203	408	490	185	146	122	4-18
100	229	20	229	471	573	215	178	154	4-18
150	267	23	267	593	743	280	235	207	8-22
200	292	23	292	774	975	335	292	264	8-22
250	330	24	330	940	1190	405	356	328	12-22
300	356	30	356	1065	1370	455	406	374	12-26

Note: Watermarked sizes are DN80-300 Flanged, DN80-150 Grooved.

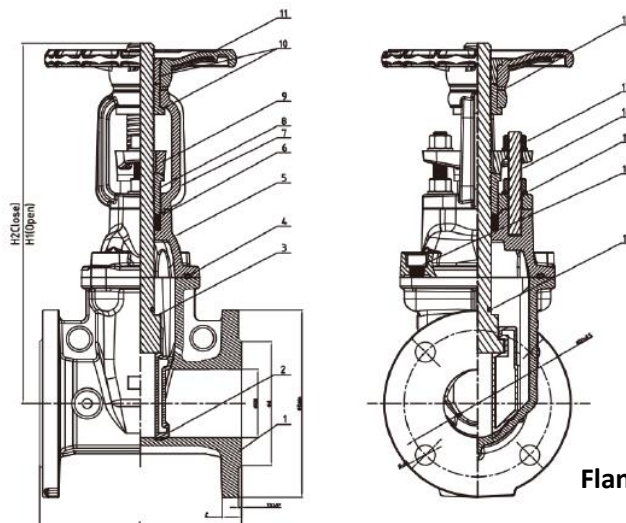

Flanged Model Drawing

(Grooved drawing on request.)